

# PM150/PM240 Installation manual



## Warranty

All Polyamp DC/DC converters are warranted against defective material and workmanship. This warranty is valid for 24 months from the date of delivery. We will repair or replace products which prove to be defective during the warranty period. The warranty is valid only if the converter is used within specification.

## Manual

This manual is as complete and actual as possible at the time of printing. However, the information may have been updated since then. Polyamp AB reserves the right to make changes in this manual without notice.



The exclamation point within an equilateral triangle is intended to alert the user to presence of important operating and maintenance instructions in the literature accompanying



The lightning flash with arrowhead, within an equilateral triangle, is intended to alert the user to presence of uninsulated "dangerous voltage" within the products enclosure that may be of sufficient magnitude to constitute a risk of electric shock to persons

### Caution!

To prevent the risk of electric shock, do not open enclosure. No serviceable parts inside. Refer servicing to qualified service personnel only

## **CONTENTS**

<b>1 BEFORE INSTALLATION</b> .....	<b>4</b>
<b>2 INSTALLATION</b> .....	<b>4</b>
<b>3 PARALLEL CONNECTION</b> .....	<b>5</b>
3.1 SERIES DIODE ON THE OUTPUT .....	5
3.2 CONNECTING CONVERTERS IN PARALLEL ON THE OUTPUT.....	5
3.3 ADJUSTING OUTPUT VOLTAGE WHEN UNITS ARE PARALLELED ON THE OUTPUT.....	5
<b>4 MULTIPLE LOADS AT THE OUTPUT</b> .....	<b>6</b>
4.1 SHORT-CIRCUITS.....	6
<b>5 ALARM</b> .....	<b>7</b>
<b>6 OUTPUT OVER VOLTAGE PROTECTION</b> .....	<b>7</b>
<b>7 ISOLATION VOLTAGE TEST</b> .....	<b>7</b>
7.1 DC ISOLATION TEST OUTPUT TO CASE.....	7
7.2 AC ISOLATION TEST OUTPUT TO CASE.....	8
7.3 DC ISOLATION TEST INPUT TO OUTPUT AND INPUT TO CASE .....	8
7.4 AC ISOLATION TEST INPUT TO OUTPUT AND INPUT TO CASE .....	8
<b>8 OPTION H, INRUSH CURRENT LIMIT</b> .....	<b>8</b>
<b>9 TROUBLE SHOOTING</b> .....	<b>9</b>
9.1 THERE IS NO OUTPUT VOLTAGE.....	9
9.2 THE INPUT FUSE BLOWS WHEN THE INPUT IS CONNECTED .....	9
9.3 THE CONVERTER STARTS AND STOPS REPEATEDLY .....	9
9.4 FAULT REPORT.....	9

### 1 Before installation

On the front panel label the following is displayed: Converter type name, input voltage range, nominal output voltage, serial number, options, article number, isolation voltages and ambient temperature range. The converter type name consists of model name PM150 or PM240 followed by input code and output voltage. Two examples:

- "Type: PM150B24" has input code "B" and nominal output voltage 24Vd.c.
- "Type: PM240 110/48" has input code "110" and nominal output voltage 48Vd.c.

Input, output and case are galvanically separated from each other. You can thus choose how you want the system connected.

The input is protected against reverse polarity by a parallel diode at the input on models with input code A, B, 24 and 48. This diode, however, is only intended to blow an external input fuse. C, D, 110 and 220 input codes have a series diode.

The input should be fused. See *Table 1*.

**PM150 input fuses**

Input voltage code	Time delay fuse
A	20 A
B	10 A
C	4 A
D	2.5 A

**PM240 input fuses**

Input voltage code	Time delay fuse
24	15 A
48	8 A
110	4 A
220	2 A

**Table 1. Recommended input fuses.**

There are two reasons we do not include the fuse.

1. DC-networks should be fused at the distribution point to protect the cable.
2. Different applications require different types of fuses.

If the converter is mounted in an electric vehicle, an external series diode on the input is recommended. Please contact your Polyamp dealer.

If the converter supplies a DC-motor, we recommend an external parallel diode at the motor poles to protect against reverse voltages.

For the disconnection ability, an external disconnection device shall be incorporated with the input power supply cord.

### 2 Installation

The converter is supplied with mounting plates. With these you can mount the converter in any direction. The converter is convection cooled and in order to get sufficient cooling there shall be a minimum of 30 to 50 mm space at upper and lower parts of the converter. If this is not possible, we recommend the use of an external fan.

Note that the expected life of the converter is dependant on converter temperature. For every 10°C that the temperature is lowered the expected life is approximately doubled. It is therefore crucial to cater for good ventilation and if possible to reduce ambient temperature.

To meet the EMC specifications in the enclosed "declaration of conformity" use twisted-pairs for connecting input, output and alarm. Shielded cables are not necessary.

1. Connect protective earth.
2. Connect the output. The converter output is short-circuit proof by a constant current limit which works unlimited in time. Therefore there is no need to fuse the load (unless you use multiple loads, see below). The current limit is fixed to 105% of nominal output current.
  - If the converter is to be connected in parallel at the output, please consult *3 Parallel connection* on page 5.
  - If you use multiple loads, please consult *4 Multiple loads at the output* on page 6.
  - If you intend to use the alarm, please consult *5 Alarm* on page 7.
3. Start the converter with your external input disconnection device.

#### **Beware of hazardous voltages!**

- The output voltage can be adjusted +10% to -5% of nominal output voltage with the potentiometer marked V.ADJ on the front panel. Clockwise turn increases the output voltage. The potentiometer has 15 turns. If you have connected units in parallel on the output, the procedure of adjusting the output voltage is described in 3.3

*Adjusting output voltage when units are paralleled* on the output on page 5.

4. When the converter is disconnected, switch-off the input voltage with the disconnecting unit. Disconnect the input cables first, then output and last the protective case connection.

### 3 Parallel connection

If a redundant power supply system is requested, two or more converters can be connected in parallel. To achieve redundancy the number of converters must be dimensioned to carry the whole load even if one converter is faulty. Connect your load to the + output after the series diode (cathode), see *Figure 1*.

Another reason for connecting two or more converters in parallel is to get more power. Use the output with series diode, see *Figure 1*.

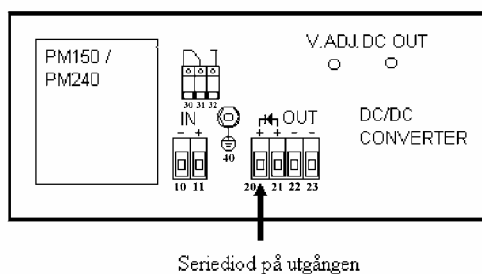

**Figure 1.** The series diode output marked with an arrow

#### 3.1 Series diode on the output

The series diode protects the converter output from external voltage sources. A series diode is necessary if the output is connected in parallel with another power supply or if you require redundant operation. If a converter breaks down with an internal short-circuit on the output and other converters are connected in parallel on the output, the broken unit will short-circuit the others if the series diode is not used. This might cause excessive heat or even fire in the faulty unit.

If the series diode is used, the alarm relay will switch to "ALARM" on the faulty unit if one converter breaks down in a redundant power supply system. Otherwise there will be no alarm indication from a faulty converter unless all units are in current limit and the output voltage drops 10% below nominal output voltage.

Do not forget to fuse the inputs separately to achieve redundancy.

#### 3.2 Connecting converters in parallel on the output

The expected life of the converter is dependant on converter temperature. It is therefore important for

paralleled unit to share the load as equal as possible to reduce the converter temperature. To achieve good current sharing the converters must have separate cables to the load. The cables should be dimensioned to have a voltage drop,  $U_d$ , between the converter and the load at maximum current capacity, see *Figure 2* and *Figure 3*.

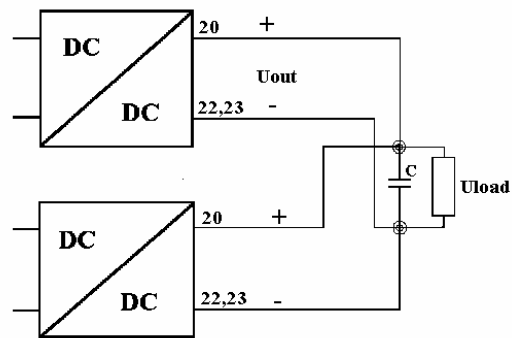

**Figure 2.** Voltage drop  $U_d = U_{out} - U_{load}$

- When the series diode is used, which we recommend, the voltage drop should be approximately 1.0% of nominal output voltage (to also compensate for the negative temperature coefficient of the diode).
- When the series diode is **not** used, **this is not recommended**, the voltage drop should be approximately 0.5% of nominal output voltage.

Note that the voltage drop affects the load regulation (the voltage at the load), see *Figure 3*.

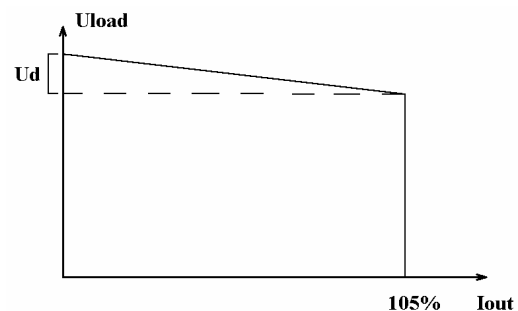

**Figure 3.** Load regulation with voltage drop  $U_d$  between output and load

#### 3.3 Adjusting output voltage when units are paralleled on the output

1. Connect and start all converters according to 2 Installation on page 4. We recommend using the series diode and separate cables as mentioned

above in 3.2 *Connecting converters in parallel on the output.*

2. Measure the voltage at the load. Connect voltmeters as showed in *Figure 4*. If you have only access to one voltmeter you must move it around to make the adjustments. This will take

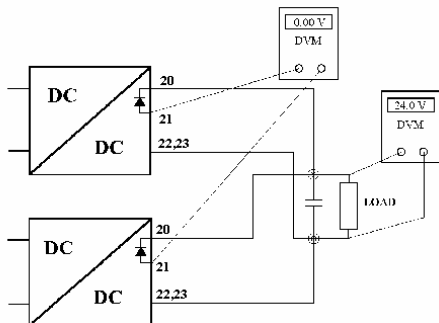

time but is of course possible.

**Figure 4. Adjusting output voltage**

3. To **increase** the output voltage.
  - i. Increase the output voltage by turning the potentiometer marked "V.ADJ" clockwise on the unit with the lowest output voltage until you reach the desired voltage at the load or until the output voltage does not increase anymore (as the unit is in current limit). To find the unit with the lowest output voltage you can measure the voltage difference before the series diode, as in *Figure 4*.
  - ii. Repeat from i. until you reach the desired output voltage at the load.
4. To **decrease** the output voltage.
  - i. Decrease the output voltage by turning the potentiometer marked "V.ADJ" counter clockwise on the unit with the highest output voltage until you reach the desired voltage at the load or until the output voltage does not decrease anymore (as the other units supply all current). To find the unit with the highest output voltage, measure the voltage difference before the series diode, as in *Figure 4*.
  - ii. Repeat from i. until you reach the desired output voltage at the load.
5. To achieve good current sharing, adjust all converters so that the voltage difference before the series diode is 0.00V between all units that

are connected in parallel and so that the voltage at the load is still the desired.

## 4 Multiple loads at the output

If you are using several loads, we recommend fusing them separately with fast acting fuses. Some considerations regarding short-circuits should be taken. See below.

### 4.1 Short-circuits

1. If there is a short-circuit in one branch and the total current in all branches **does not** exceed 105% of the nominal current of the converter (see label on front panel), the output voltage will not be affected. The time for the fuse to blow can be calculated from the data sheet of the fuse if you know the short-circuit current trough the fuse.
2. If there is a short-circuit in one branch and the total current in all branches **does** exceed 105% of the nominal current of the converter, the output voltage will drop until the fuse is blown. Depending on the impedance of the short-circuit (whether it is abrupt or merely an overload) and the resistance of the load cables, the effects of a short-circuit will vary.

Long cables reduce short-circuit currents, resulting in longer delay until the fuse is blown and hence an increased voltage dip. Light overload does not necessarily result in a blown fuse.

To reduce the voltage drop at short-circuit and if any branch has more than approximately 30% of the total output current of the converter, a large external capacitor is recommended. Such a capacitor will supply the peak current needed to blow the fuse, see *Figure 5*. To calculate the capacitor needed, use the following formula:

$$C = 1.2 \times ( I_s \times \Delta t ) / \Delta U$$

1.2 = Safety margin.

$I_s$  = Short-circuit current through the fuse.

$\Delta t$  = Time before the fuse blows (see data sheet on the fuse).

$\Delta U$  = Acceptable voltage dip before the fuse blows.

Example:

You have a 1A fuse with fast characteristic and the short-circuit current is 10A. The data sheet gives you that  $\Delta t = 10\text{ms}$ . The output voltage is 24V, and you can accept 10% voltage drop  $\Rightarrow \Delta U = 24 \times 0.1 = 2.4\text{V}$ .

The capacitance you need:

$$C = 1.2 \times (I_S \times \Delta t) / \Delta U = 1.2 \times 10 \times 0.01 / 2.4 = 50,000\mu\text{F}$$

Choose a capacitance with a rated voltage of at least 115% of nominal output voltage of the converter.

Repeat this calculation for all branches and choose the highest capacitance value.

- It is sometimes difficult to estimate the short-circuit current when the nature of a fault is unknown. In this case a voltage dip might appear under some short-circuit conditions even with a large capacitor present. If a voltage dip is critical in one branch it is recommended to use a separate DC/DC converter supplying this branch.

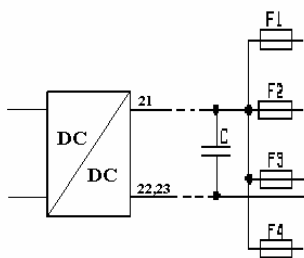

Figure 5. Connecting multiple loads.

## 5 Alarm

The alarm relay switches to "ALARM" state if:

- The output voltage is not within +15% /-10% of nominal output voltage.

Otherwise the relay contact is in the position "NORMAL".

The alarm relay can be connected in two ways:

- Normally Open (NO).
  - Connect twisted-pair (0.25mm<sup>2</sup> -1.5mm<sup>2</sup>) from centre pin of the removable alarm connector and connector pin marked "ALARM".

- Normally Closed (NC).
  - Connect twisted-pair (0.25mm<sup>2</sup> -1.5mm<sup>2</sup>) from centre pin of the removable alarm connector and connector pin marked "NORMAL".

The relay is isolated 2500Va.c. from input, output and case. The relay can switch maximum 30V/5A (a.c. and d.c. values).

## 6 Output over voltage protection

All models are equipped with an internal output over voltage protection circuit (OVP). It consists of an additional voltage regulator operating in parallel with the main regulator. The output voltage is limited to approximately 15% above the nominal output voltage. As long as the OVP circuit is active the alarm relay is set to "ALARM" state.

## 7 Isolation voltage test

Each converter has been isolation tested in factory before delivery. **Warning! An isolation test shall only be performed by personnel aware of the dangers and hazards of the test.**

The isolation voltage is 2500Va.c. on all models. If your isolation test equipment cannot supply this current, you can perform a DC isolation test with 4000Vd.c (2500V x  $\sqrt{2}$  x 1.1  $\approx$  4000Vd.c where 1.1 = safety factor).

### 7.1 DC isolation test output to case

- Disconnect all cables from the converter.
- Connect the input terminals of the converter to case.
- Connect the output terminals together.
- Connect your isolation tester between output and case. See *Figure 6*. Raise the voltage of the isolation tester from 0 to 4000Vd.c. Check that the leakage current does not exceed 5 $\mu$ A. The voltage should not be applied for more than a few seconds or the Y-capacitors might be damaged.
- Turn off the isolation tester and discharge the test voltage with a 10 M $\Omega$  resistor between output and case.

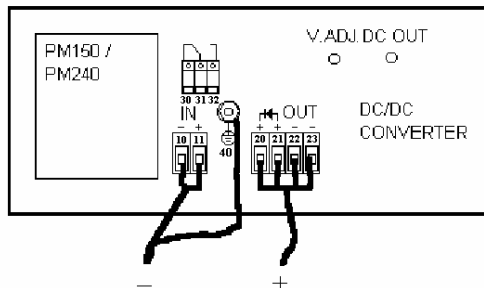

Figure 6. Output to case isolation voltage test.

### 7.2 AC isolation test output to case

**Beware of the rather high capacitive earth currents (about 100mA) that will occur during this test.**

1. Disconnect all cables from the converter.
2. Connect the input terminals of the converter to case.
3. Connect the output terminals together.
4. Connect your isolation tester between output and case. See *Figure 6*. Raise the voltage of the isolation tester from 0 to 2500Va.c. The voltage should not be applied for more than one (1) minute or the Y-capacitors might be damaged.
5. Turn off the isolation tester and discharge the test voltage with a 10 M $\Omega$  resistor between output and case.

### 7.3 DC isolation test input to output and input to case

1. Disconnect all cables from the converter.
2. Connect the output terminals of the converter to case.
3. Connect the input terminals together.
4. Connect your isolation tester between input and case. See *Figure 7*. Raise the voltage of the isolation tester from 0 to 4000Vd.c. Check that the leakage current does not exceed 5 $\mu$ A. The voltage should not be applied for more than a few seconds or the Y-capacitors might be damaged.
5. Turn off the isolation tester and discharge the test voltage with a 10 M $\Omega$  resistor between input and case.

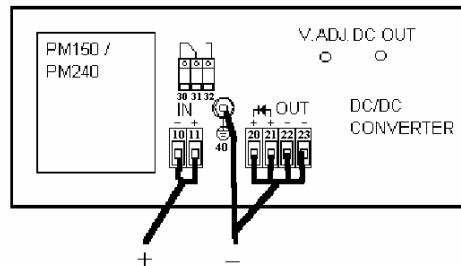

Figure 7. Input to output and input to case isolation voltage test.

### 7.4 AC isolation test input to output and input to case

**Beware of the rather high capacitive earth currents (about 100mA) that will occur during this test.**

1. Disconnect all cables from the converter.
2. Connect the output terminals of the converter to case. See *Figure 7*.
3. Connect the input terminals together.
4. Connect your isolation tester between input and case. See *Figure 7*. Raise the voltage of the isolation tester from 0 to 2500Va.c. The voltage should not be applied for more than one (1) minute or the Y-capacitors might be damaged.
5. Turn off the isolation tester and discharge the test voltage with a 10 M $\Omega$  resistor between input and case.

## 8 Option H, inrush current limit

Converters marked with "Options: H" on the front label are equipped with "inrush current limit" feature. The input capacitors are charged through an NTC resistor to reduce the input current during start up. This feature is only available on the PM150 models with input codes B, C and D.

The input voltage range is changed when this option is included, see *Table 2*. This is because if the load changes from 0 to 100% abruptly, the input current also changes abruptly. This will cause a voltage drop across the NTC resistor (until it heats up). If the input voltage is only slightly higher than the start voltage of the converter this voltage drop will cause the converter to stop. The converter will then start and stop several times until the NTC resistor is heated up. We have therefore increased the lowest input voltage on units with a NTC resistor so this behaviour not arises.



PM150 (normal input voltage range)	
Input voltage code	Input voltage range
B	20-60Vd.c.
C	50-150Vd.c.
D	90-270Vd.c.

PM150 with option H	
Input voltage code	Input voltage range
B	30-60Vd.c.
C	75-150Vd.c.
D	115-270Vd.c.

**Table 2. Input voltage range with and without option H**

The unit starts if the voltage is within the normal input voltage range, but depending on the load (if the NTC is heated up) a load change might cause the converter to stop and start as described before.

All models have a "slow start" feature. To reduce input current during start up the output capacitors are charged "slowly" (approximately 0.1s).

## 9 Trouble shooting

### 9.1 There is no output voltage

1. Check that the input fuse is not broken.
2. Check that the input voltage polarity is correct.
3. Check that the input voltage is within the specified limits, see front label.
4. The converter may be in current limit due to excessive output current or an external short-circuit on the output.
  - Disconnect the input.
  - Disconnect the load.
  - Connect the input again and measure the output voltage.

If the converter now starts the load was too heavy or there was a short-circuit.

- If there is an external short-circuit, remove it.
  - If the load is too large decrease the load or consult your Polyamp dealer.
5. The unit is broken. Contact your Polyamp dealer.

### 9.2 The input fuse blows when the input is connected

1. Check that the input voltage polarity is correct.
2. Check that the input fuse is of time delay type and with correct current rating. See *Table 1*.
3. The unit is broken. Contact your Polyamp dealer.

### 9.3 The converter starts and stops repeatedly

All models have an over/under voltage protection which shuts down the converter if the input voltage is not within specified limits (see front label).

1. The cables to the converter input may be undersized, causing too high voltage drop in the supply cables.
2. Your supply does not have enough current capacity so the input voltage to the converter drops below specified limit.

### 9.4 Fault report

We suggest that you return a faulty converter to:

POLYAMP AB  
Box 229 / Bäckgatan 10  
S-597 25 ÅTVIDABERG  
SWEDEN

Tel: +46 120 85400  
Fax: +46 120 85405

or to your local Polyamp distributor.

To help us locate the fault, please describe the fault and how and when it occurred.